



---

# Radiance Hazer

## Operators Manual

## Table of Contents

Introduction .....	1
Warning .....	1
Safety Precautions .....	1
Technical Specifications .....	2
Technical Drawings .....	2
Radiance Setup.....	3
Operating Procedure .....	3
Stand Alone Operation .....	3
DMX Operation .....	4
RDM Functions.....	4
Operation with Hand Remote.....	5
Maintenance Procedure .....	6
Troubleshooting.....	6
Recommended Fluid .....	6
Warranty .....	7
Contact Information .....	8



# Introduction

Ultratec Special Effects Radiance Haze Machine is a major advancement in Water Based Haze Technology. Once again, Ultratec Special Effects is setting new standards that all other haze machines will be measured against.

Features include:      Digital DMX address display.  
                                 Built-In DMX that controls both the Haze Output and the Internal Fan.

This combination offers excellent haze control and even dispersion. The Radiance can also be operated by an optional remote or by utilizing the Onboard Variable Settings. Additional features include an IEC removable power cable and multi-use bracket.

The Radiance uses only Ultratec Special Effects Luminous 7 Haze Fluid which is a proven fluid that offers the best in low consumption with superior visual hang time. It can accommodate both the 2L or 4L sizes of the Ultratec fluid containers.



## Warning!!



## Important Safety Instructions:

1. Do not touch, place hands or expose skin within 20”(50cm) of the discharge nozzle.
2. Do not remove the outer case.
3. Persons suffering from asthma or allergenic sensitivity may experience irritation, discomfort or allergic symptoms when exposed to fog effects.
4. Ensure that this unit is grounded at all times. Failure to do so may result in serious injury.
5. Use Ultratec Special Effects Luminous 7 Water Base Haze Fluid **ONLY**. A Luminous 7 SDS is available at [www.ultratecfx.com](http://www.ultratecfx.com)



## Safety Precautions

1. Ensure that any operation of the machine is supervised by suitably trained and authorized personnel.
2. Do not modify the machine or use a machine which has been damaged in any way.
3. Allow sufficient air circulation around the machine at all times.
4. Protect the machine from direct weather effects and wet locations. Suitable for dry locations only.
5. Only use Luminous 7 Water Base Haze Fluid by Ultratec Special Effects.
6. Do not continue to produce haze in an enclosed area when visibility is reduced below 20”(50cm).
7. Avoid direct haze output continuously at persons, structures or objects within close proximity of the discharge nozzle.
8. Ensure that adequate exhausting arrangements are available in the event of an emergency.
9. Do not place hands or exposed skin within the first 20”(50cm) of the discharge nozzle at any time during haze production.
10. Haze effects can trigger smoke alarms and detectors. Please take suitable precautions to prevent false alarms.

# Technical Specifications

Model: Radiance Hazer

Part Number: CLF2460 - Radiance Hazer -120Volt  
CLF2464 - Radiance Hazer - 220-240Volt

Length: 16.5in      41.91cm  
Width: 11in      27.94cm  
Height: 7in      18cm  
Net Weight: 28lbs      12.7kg

Power Rating: 120 Volt A.C.      50/60 Hz.      4.5 Amps.  
220-240 Volt A.C.      50/60 Hz.      2 Amps.

Fluid: Ultratec Special Effects Luminous 7 Water Base Haze  
Fluid Consumption settings from 27 - 380 cc/ hour  
Even lower output is achieved by using the Interval Timer.

Features: 5-Pin USITT DMX 512 RDM Protocol  
Truss Mount/ Angle Floor Stand  
Power Cord: 6' Detachable IEC Cord  
Heat up: 8 Minutes  
Run Time: Continuous

Approvals: 120V Full certification by T.U.V.  
CE Certified 220 VAC  
CSA/UL certified by QPS for 240 VAC

## Technical Drawings

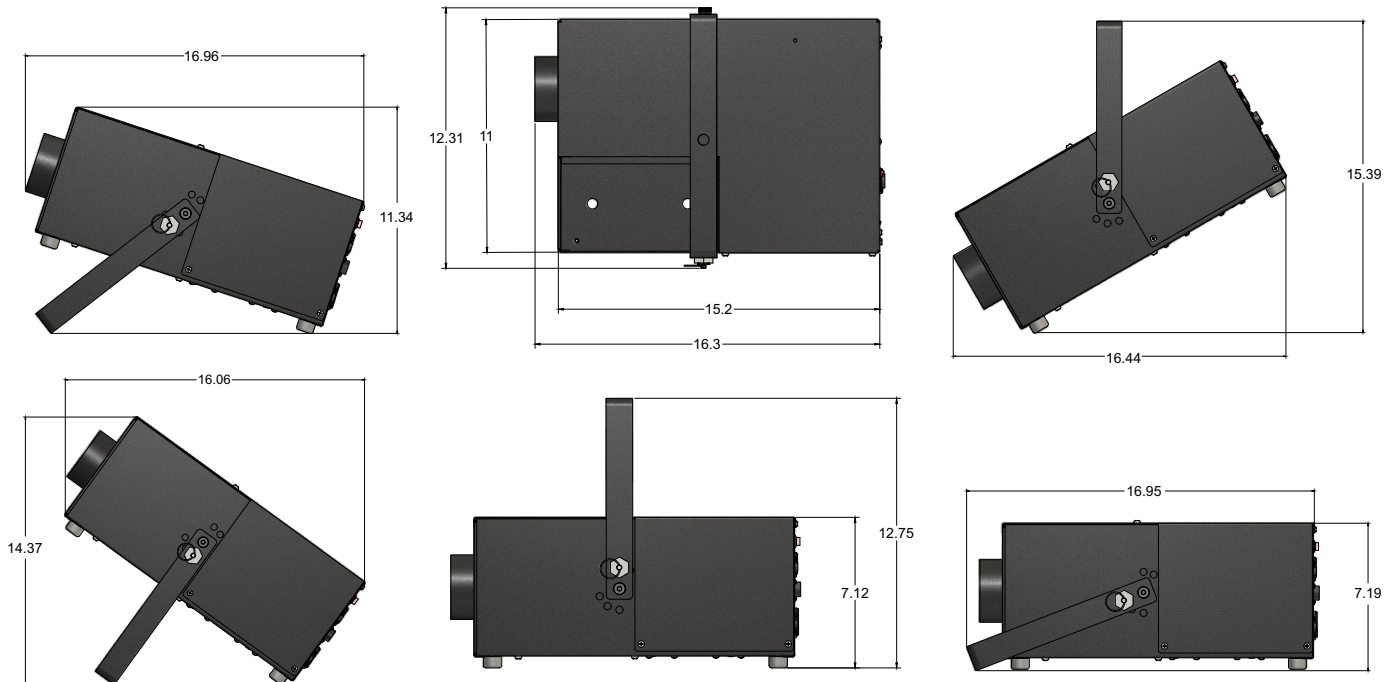

# Radiance Setup

1. Insert a 2 or 4 Liter Jug of Ultratec Special Effects Luminous 7 Haze Fluid into the fluid jug holder.
2. Remove the cap and break the foil seal. Insert the fluid pickup tube into the jug and tighten the lid. Ensure the fluid filter located at the end of the tube sits at the lowest end especially if the machine is not mounted level.
3. An optional Versa Fan can be controlled at the same rate as the internal fan. Plug a matching voltage VersaFan into the U-Ground (120 volt) or Neutrik Connector (220-240 volt). It will now vary with the internal fan control.

**Note:** The Versa Fan speed control dial needs to be switched “ON” and set to maximum for proper operation.

## Operating Procedure

After power up, the rear display will momentarily show the code revision levels in the machine and then display the DMX setting for several seconds. The display will blank after a short period of time. Touching an arrow key will relight the display. Further activation of the keys will alter the DMX setting.

## Stand Alone Operation

1. Plug the unit into a suitable power source. Turn the main power switch on and it will illuminate if power is present. The heat up time is approximately 8 minutes before haze can be produced. The Green LED indicates “heating” when flashing and “ready” when the LED is “solid”. A three-flash pattern and the fan turning on to full speed indicates an over temperature error.
2. The Haze Rate and Fan Control provides a limited range of control divided into to 8 steps plus OFF for the assist fan and the haze rate. The DMX address buttons are used to select the desired operation. Place the DMX address to 600 on the display. The display will stay illuminated indicating this mode is selected. Allow the machine to heat fully by watching the green LED progress. The ‘tens’ button controls the haze rate. 0 is off, 1-8 runs from low to full (9 is the same level as 8). For minimum Flow Rate use DMX or Optional Hand Remote Control. The ‘ones’ switch controls the assist fan in the same way, 1-8 is low to full. The Versa Fan Power Port output will also be adjusted. The fan has a minimum setting and should always run when the power is applied. The fan only runs faster when haze is requested.
3. 15 Minutes prior to shutting down your Radiance Hazer, adjust your output setting to “0” Doing this will consume any haze fluid that is still in your distribution feed tubes and processing block. Failure to do so will result in raw fluid being discharged from your output nozzle when you operate it next start-up and will help reduce (not stop) the residue buildup.

**Note:** Stand Alone Operation overrides DMX and held held remote operation controls.



# DMX Operation

1. Select the desired DMX address on the digital display for the hazer.

**Note:** The hazer occupies two sequential DMX addresses. The maximum DMX address of 511 must be set if using the last two DMX addresses in the chain.

**Note:** The display goes to sleep when not in use. Touching any key once wakens it.

The selected address is the Haze rate and the selected address + 1 is the fan speed. Control is from 0 - 100% with "0" turning the haze output off and reducing the fan to its minimum default speed. The Versa Fan Power Port output will also be adjusted.

2. Insert the DMX line into "DMX in" connector.

3. Plug the unit into a suitable power source. Turn the main power switch on and it will illuminate if power is present. The valid DMX light will be solid when DMX signal is present. The heat up time is approximately 8 minutes before haze can be produced. The Green LED on the back of the unit indicates heating when flashing and ready when solid. A three-flash pattern with the fan turning ON to full speed, indicates an over temperature error.

The fan has a minimum setting and should always run when the power is applied. The fan speed can only be changed when haze is being produced.

4. 15 Minutes prior to shutting down your Radiance Hazer, adjust your output setting to "0" Doing this will consume any haze fluid that is still in your distribution feed tubes and processing block. Failure to do so will result in raw fluid being discharged from your output nozzle when you operate it next start-up and will help reduce (not stop) the residue buildup

Note: DMX Operation overrides hand held remote operation controls.



## RDM Functions

RDM features will allow remote identify by flashing the DMX display, DMX address changing and machine temperature monitoring. As well the machine's group and manufacturer identification data are available.



# Operation with Hand Remote

1. Plug the Hand Remote cable into the rear connector marked remote.
2. Plug the unit into a suitable power source.
3. Turn the main power switch on and it will illuminate if power is present.

**Note:** For the Hand Remote to work, a valid DMX address must be set from 001 to 511.

The display goes to sleep when not in use. Touching any key once wakens it. DMX control will override the hand remote settings. DMX control is indicated when the valid DMX light is solid RED.

4. The heat up time is approximately 8 minutes before haze can be produced. The Hand Remote indicates the heating cycle when the haze switch light is flashing. When the unit is ready to haze the light will be solid. A three-flash pattern and the fan turning on to full speed indicates an over temperature error. The rear panel Green LED indicates the same status.
5. The haze rate can be switched on, off and varied by using the Hand Remote controls. Haze output increases as the variflow knob turns clockwise.
6. The assist fan is always on low. Fan speed can be increased by rotating the fan knob clockwise. The fan only speeds up during haze output. The Versa Fan Power Port output will also be adjusted.
5. The interval knob is used to provide cycled output. It must be set fully counterclockwise (off) when continuous haze output is required. The hazer will produce 10 seconds of output at the requested flow, spaced by a 1 - 300 seconds interval dependent upon the dial position.
6. 15 Minutes prior to shutting down your Radiance Hazer, adjust your haze output setting to "0" Doing this will consume any haze fluid that is still in your distribution feed tubes and processing block. Failure to do so will result in raw fluid being discharged from your output nozzle when you operate it next start-up and will help reduce (not stop) the residue buildup.

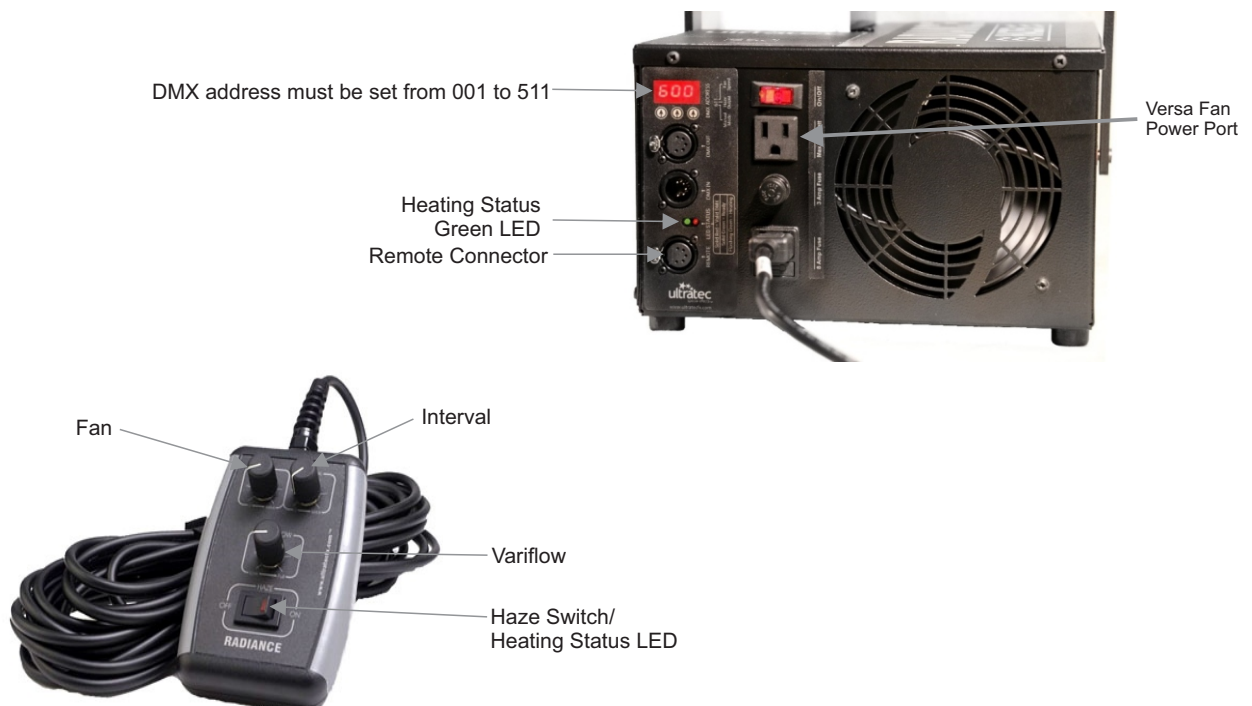

Hand Held Remote (optional)

# Maintenance Procedure

For information and instructions regarding the cleaning procedure, please refer to the “Radiance Hazer Service Manual” or “Radiance Hazer Service Maintenance Procedure Video” located on Radiance product page at [www.ultratecfx.com](http://www.ultratecfx.com)

## Troubleshooting

### UNIT NOT POWERING UP

- 1) Check that IEC power cord is securely connected to unit.
  - 2) Check that unit is connected to a suitable power source.
  - 3) Check that the power switch is in the ON position.
  - 4) Check that the 8A fuse inside the fuse powered entry module has not blown.
  - 5) Check that unit has not shutdown due to over temperature condition and that mechanical safety temperature fuse (Thermal Disc) has not open.  
Wait about 1 hour and then check again to see if temperature fuse (Thermal Disc) has reset and if unit powers back up.
- Contact Ultratec Special Effects for further help.
- 6) Check both fuses on circuit board if blown open. Note: Fuses are soldered onto circuit board.  
Contact Ultratec Special Effects for more help with this.

### UNIT DOES NOT PRODUCE HAZE

- 1) Check that fluid pick up hose is sufficiently submerged into fluid in jug.
- 2) Ensure fluid pickup line is fully primed with fluid.
- 3) Ensure that green heater status LED is ON solid, indicating that unit is fully heated.
- 4) If using Standalone Mode, ensure DMX address is set to 600 and that the 10's column is set between 1 - 8
- 5) If using DMX control, ensure that DMX address on Radiance is set between 001 to 511 range.
- 6) If using DMX control, ensure that red Valid DMX LED is ON solid and that correct DMX channel on the DMX console matches DMX address set on the Radiance.
- 7) If using hand held optional remote, ensure that DMX address on Radiance is set between 001 - 511.
- 8) If using hand held optional remote, ensure that red Valid DMX LED is not turn ON solid. This should be off.  
Remove DMX signal or cable if connected to hazer to use remote.
- 9) Check that heater block is not plugged when unit is cool. Complete heater block maintenance if necessary.
- 10) Contact Ultratec Special Effects for for further help.

### FAN NOT TURNING ON

- 1) Check the unit is connected to a suitable power source.
  - 2) Check that the power switch is in the ON position.
  - 3) Check that the fan motor and fan blades are not full of dust/debris. Disconnect power and clean fan.
  - 4) Check that fan blades spin freely with a long metal tool, when machine is powered off and disconnected from power. Fan motor / blades may be dirty and need cleaning. Fan may be seized up and need replacing.
- Contact Ultratec Special Effects for more help with this.

## Recommended Fluid

### Ultratec Special Effects Luminous 7 Haze Fluid:

This fluid was specifically designed to be used in our Radiance Haze Machine. This water-based fluid creates an evenly dispersed haze that is dry and long lasting without leaving any residue. It produces a premium quality, beautiful haze that illuminates the light and laser beams from ceiling to the floor. Luminous 7 Haze Fluid has a high concentration of an active ingredient that allows for low fluid consumption and is completely safe.



Ultratec Special Effects Luminous 7 Haze Fluid



# Warranty

Hardware products come with a five-year warranty on parts and labor. If the unit in question has a material defect or fault that is caused in manufacturing, Ultratec Special Effects will provide free parts and labor to remedy the equipment. Ultratec Special Effects service department must be advised in a timely manner after defect appearance and the date of warranty request must be within five years of sale/purchase. Proof of sale and/or proof of purchase will be required for warranty to take effect.

Warranty service will be performed as follows: faulty parts will be repaired or replaced with the same or comparable parts, based on availability. Freight to our facility for warranty requests will be prepaid by the user/dealer. Upon completion of the repair, Ultratec Special Effects will return the unit via the most economical means available. Should you require the item express-returned, the user/dealer is responsible for indicating this request and for any difference in freight cost.

Warranty will be voided, and customer will lose all rights guaranteed by the warranty if any of the following are observed/occur:

If any non Ultratec Special Effects fluid is used at any point of operation.

If any adjustments or repairs are done to the machine in question by repair technicians not authorized by Ultratec Special Effects.

If our repair technicians observe any signs of incorrect handling/treating of machine in question.

Warranty services do not cause an extension of the warranty nor does a repaired product start a new warranty. This warranty only applies to the product supplied by Ultratec Special Effects, Ultratec Special Effects is not responsible for any losses, costs, or damages from the use of a defective product.

Any additional costs incurred are the responsibility of the Dealer and/ or the customer.

An RA (Return Authorization) number must be noted on the outside of each box being returned to our facility. Any package(s) without an RA number clearly marked, will not be accepted by our receiving department.

Export Distributors are required to carry out the warranty repair, parts will be supplied by Ultratec.

Please do not forget to remove any liquid from the machine when sending in for repair.

Please remember to include the RA Number on all items being shipped in for repairs.

To request a Return Authorization number please refer to our website - instructions below:

- 1) [www.ultratecfx.com](http://www.ultratecfx.com)
- 2) Click on the SUPPORT tab along the top of the screen
- 3) Click on REQUEST RMA from the pull down
- 4) Fill in the required information
- 5) Click on "SEND" button

If you have any questions or require assistance please contact service at 519-951-3355/866-534-5557 or by email at [Service@Ultratecfx.com](mailto:Service@Ultratecfx.com).

# Contact Us

## Head Office

Ultratec Special Effects  
1960 Blue Heron Drive  
London, Ontario N6H 5L9  
Direct: 519-659-7972  
Toll Free: 800-388-0617  
Fax: 519-659-7713

## Europe Office

Ultratec Special Effects GmbH  
Dieselstrasse 30-40  
60314  
Frankfurt am Main  
Germany  
Direct: 49-69-87-000-1850  
Fax: 49-69-87-000-1899

## USA Shipping Address

(For All USA Repairs)  
Ultratec Special Effects  
640 Gadson Street  
Groveland, Florida 34736

## Canadian Shipping Address

(For All Canadian Repairs)  
Ultratec Special Effects  
1960 Blue Heron Drive  
London, Ontario N6H 5L9

